

Compact High capacity, Natural Cooling Power Supply Range from 0.65 A up to 20 A with Output Voltage of 24 VDC

- Only 6 models to cover all applications
- EMI Class B Compliant
- Output indicator LED green
- Mount to DIN Rail.
- Complies with SEMI F47-0200 (200 VAC input).
- RoHS-compliant.
- Safety standards:
UL508/60950-1,
CSA C22.2 No. 107.1/60950-1 (60 W to 480 W),
EN50178 (= VDE0160),
EN60950-1 (= VDE0805 Teil 1)



Note: Refer to *Safety Precautions* on page 11

Model Number Structure

Model Number Legend

S8VS-
 1 2

1. Power Ratings

- 015: 15 W
- 030: 30 W
- 060: 60 W
- 120: 120 W
- 240: 240 W
- 480: 480 W

2. Output voltage

- 24: 24 V

Ordering Information

List of Models

Power ratings	Input voltage	Output voltage	Output current	Model number
15 W	100 to 240 VAC	24 VDC	0.65 A	S8VS-01524
30 W			1.3 A	S8VS-03024
60 W			2.5 A	S8VS-06024
120 W			5 A	S8VS-12024
240 W			10 A	S8VS-24024
480 W			20 A Peak current 30 A (200 VAC)	S8VS-48024

Specifications

Ratings/Characteristics

Item	Power ratings	15 W	30 W	60 W	
Efficiency (typical)		77% min.	80% min.	78% min.	
Input	Voltage*1	100 to 240 VAC (85 to 264 VAC)			
	Frequency *1	50/60 Hz (47 to 450 Hz)			
	Current	100 V input	0.45 A max.	0.9 A max.	1.7 A max.
		200 V input	0.25 A max.	0.6 A max.	1.0 A max.
	Power factor	---			
	Harmonic current emissions	Conforms to EN61000-3-2			
	Leakage current	100 V input	0.5 mA max.		
		200 V input	1.0 mA max.		
Inrush current *2	100 V input	25 A max. (for a cold start at 25°C)			
	200 V input	50 A max. (for a cold start at 25°C)			
Output	Voltage adjustment range *3	-10% to 15% (with V.ADJ)			
	Ripple	2.0% (p-p) max. (at rated input/output voltage)			
	Input variation influence	0.5% max. (at 85 to 264 VAC input, 100% load)			
	Load variation influence (rated input voltage)	2.0% max. (5 V), 1.5% max. (12 V, 24 V), (with rated input, 0 to 100% load)		1.5% max. (with rated input, 0 to 100% load)	
	Temperature variation influence	0.05%/°C max.			
	Startup time *2	100 ms max. (at rated input/output voltage)		1,000 ms max. (at rated input/output voltage)	
		Hold time *2			
Additional functions	Overload protection *2	105% to 160% of rated load current, voltage drop, automatic reset		105% to 160% of rated load current, voltage drop, intermittent operation, automatic reset	
	Overvoltage protection *2	Yes (a zener diode clamp) *4	Yes *5	Yes	
	Undervoltage alarm indication	Yes (color: red)		No	
	Parallel operation	No			
	Series operation	Yes for up to 2 Power Supplies (with external diode)			
Other	Operating ambient temperature	Refer to the derating curve in <i>Engineering Data</i> . (with no icing or condensation)			
	Storage temperature	-25 to 65°C			
	Operating ambient humidity	25% to 85% (Storage humidity: 25% to 90%)			
	Dielectric strength	3.0 kVAC for 1 min. (between all inputs and outputs; detection current: 20 mA)			
		2.0 kVAC for 1 min. (between all inputs and PE terminals; detection current: 20 mA)			
		1.0 kVAC for 1 min. (between all outputs and PE terminals; detection current: 20 mA)			
	Insulation resistance	500 VAC for 1 min. (between all outputs and alarm outputs; detection current: 20 mA) (only for 60 W)			
		100 MΩ min. (between all outputs and all inputs/ PE terminals) at 500 VDC			
	Vibration resistance	10 to 55 Hz, 0.375-mm single amplitude for 2 h each in X, Y, and Z directions			
		10 to 150 Hz, 0.35-mm single amplitude (5 G max.) for 80 min each in X, Y, and Z directions (only for 60 W)			
	Shock resistance	150 m/s ² , 3 times each in ±X, ±Y, and ±Z directions			
	Output indicator	Yes (color: green)			
	EMI	Conducted Emissions	Conforms to EN61204-3 EN55011 Class B and based on FCC Class A		Conforms to EN61204-3 EN55011 Group 1 Class B and based on FCC Class A
		Radiated Emissions	Conforms to EN61204-3 EN55011 Class B		Conforms to EN61204-3 EN55011 Group 1 Class B
	EMS	Conforms to EN61204-3 high severity levels			
Approved standards	UL: UL508 (Listing; Class 2: Per UL1310), UL60950-1, UL1604 (Class I/Division2) cUL: CSA C22.2 No.14 (Class 2), No.60950-1, No.213 (Class I/Division2) cUL: CSA C22.2 No.14 (Class 2), No.60950-1, No.213 (Class I/Division2) EN/VDE: EN50178 (=VDE0160), EN60950-1 (SELV) (=VDE0805 Teil 1) According to VDE0106/P100, IP20 (except terminal block)		UL for standard models: UL508 (Listing; Class 2:Per UL1310), UL60950-1 cUL: CSA C22.2 No.107.1(Class 2: Per CSA C22.2 No. 223) cUR: CSA No.60950-1 EN/VDE: EN50178 (= VDE0160), EN60950-1 (SELV) (= VDE0805 Teil 1) According to VDE 0106/P100, IP20 (except terminal block)		
SEMI	F47-0200 (200 VAC input)				
MTBF *7	> 500,000 hrs		> 250,000 hrs		
Weight	160 g max.		180 g max.		
				330 g max.	

*1) Do not use an inverter output for the Power Supply. Inverters with an output frequency of 50/60 Hz are available, but the rise in the internal temperature of the Power Supply may result in ignition or burning.

*2) Refer to *Engineering Data* on page 7 for details.

*3) If the output voltage adjuster (V. ADJ) is turned, the voltage will increase by more than +15% of the voltage adjustment range. When adjusting the output voltage, confirm the actual output voltage from the Power Supply and be sure that the load is not damaged.

Item	Power ratings		120 W	240 W	480 W	
Efficiency (typical)			80% min.		83% min.	
Input	Voltage *1		100 to 240 VAC (85 to 264 VAC)			
	Frequency *1		50/60 Hz (47 to 63 Hz)			
	Current	100 V input	1.9 A max.	3.8 A max.	7.4 A max.	
		200 V input	1.1 A max.	2.0 A max.	3.9 A max.	
	Power factor		0.95 min.			
	Harmonic current emissions		Conforms to EN61000-3-2			
	Leakage current	100 V input	0.5 mA max.			
		200 V input	1.0 mA max.			
Inrush current *2	100 V input	25 A max. (for a cold start at 25°C)				
	200 V input	50 A max. (for a cold start at 25°C)				
Output	Voltage adjustment range *3		-10% to 15% (with V.ADJ) (guaranteed)			
	Ripple		2.0% (p-p) max. (at rated input/output voltage)			
	Input variation influence		0.5% max. (at 85 to 264 VAC input, 100% load)			
	Load variation influence (rated input voltage)		1.5% max. (with rated input, 0 to 100% load)			
	Temperature variation influence		0.05%/°C max.			
	Startup time *2		1,000 ms max. (at rated input/output voltage)			
	Hold time *2		20 ms min. (at rated input/output voltage)			
	Additional functions	Overload protection *2		105% to 160% of rated load current, voltage drop, intermittent, automatic reset	105% to 160% of rated load current, voltage drop, automatic reset	
Overvoltage protection *2		Yes				
Parallel operation		No				
Series operation		Yes for up to 2 Power Supplies (with external diode)				
Other	Operating ambient temperature		Refer to the derating curve in <i>Engineering Data</i> . (with no icing or condensation)			
	Storage temperature		-25 to 65°C			
	Operating ambient humidity		25% to 85% (Storage humidity: 25% to 90%)			
	Dielectric strength		3.0 kVAC for 1 min. (between all inputs and outputs/ alarm outputs; detection current: 20 mA) 2.0 kVAC for 1 min. (between all inputs and PE terminals; detection current: 20 mA) 1.0 kVAC for 1 min. (between all outputs/ alarm outputs and PE terminals; detection current: 240 W, 20 mA/ 480 W, 30 mA) 500 VAC for 1 min. (between all outputs and alarm outputs; detection current: 20 mA)			
	Insulation resistance		100 MΩ min. (between all outputs/ alarm outputs and all inputs/ PE terminals) at 500 VDC			
	Vibration resistance		10 to 55 Hz, 0.375-mm single amplitude for 2 h each in X, Y, and Z directions 10 to 150 Hz, 0.35-mm single amplitude (5 G max.) for 80 min each in X, Y, and Z directions (only for 240 W) 10 to 150 Hz, 0.35-mm single amplitude (3 G max.) for 80 min each in X, Y, and Z directions (only for 480 W)			
	Shock resistance		150 m/s ² , 3 times each in ±X, ±Y, and ±Z directions			
	Output indicator		Yes (color: green)			
	EMI	Conducted Emissions	Conforms to EN61204-3 EN55011 Group 1 Class B and based on FCC Class A		Conforms to EN61204-3 EN55011 Class A and based on FCC Class A Conforms to EN61204-3 EN55011 Class B *6	
		Radiated Emissions	Conforms to EN61204-3 EN55011 Group 1 Class B		Conforms to EN61204-3 EN55011 Class A Conforms to EN61204-3 EN55011 Class B *6	
	EMS		Conforms to EN61204-3 high severity levels			
	Approved standards		UL: UL508 (Listing), UL60950-1 cUL: CSA C22.2 No. 107.1 UL: UL508 (Listing), UL60950-1 cUR: CSA No. 60950-1 EN/VDE: EN50178 (= VDE0160), EN60950-1 (SELV) (= VDE0805 Teil 1) According to VDE0106/P100, IP20 (except terminal block)		UL: UL508 (Listing), UL60950-1 cUL: CSA C22.2 No. 107.1 UL: UL508 (Listing), UL60950-1 cUR: CSA No. 60950-1 EN/VDE: EN50178 (= VDE0160), EN60950-1 (SELV) (= VDE0805 Teil 1) According to VDE0106/P100, IP20 (except terminal block)	
	SEMI		F47-0200 (200 VAC input)			
	MTBF*7		>250,000 hrs			
	Weight		550 g max.	1,150 g max.	1,700 g max.	

*4) The overvoltage protection of the S8VS-01524 uses a zener diode clamp. If the internal feedback circuit is destroyed by any chance, the load may be destroyed by the clamped output voltage (approx. 140% to 190% of the rated output voltage).

*5) To reset the protection, turn OFF the input power for three minutes or longer and then turn it back ON.

*6) To ensure the emission rating, a ferrite ring core should be used in all cabling (SEIWA E04SR301334 or equivalent model).

*7) MTBF stands for mean Time Between Failures, which is calculated according to the probability of accidental device failures, and indicates reliability of devices.

Connections

Block Diagrams

S8VS-01524 (15 W)

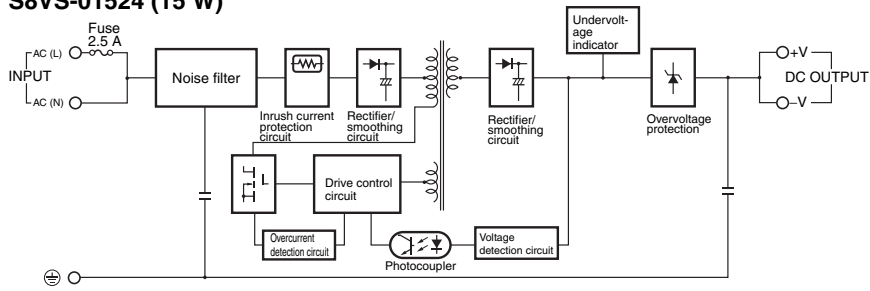

S8VS-03024 (30 W)

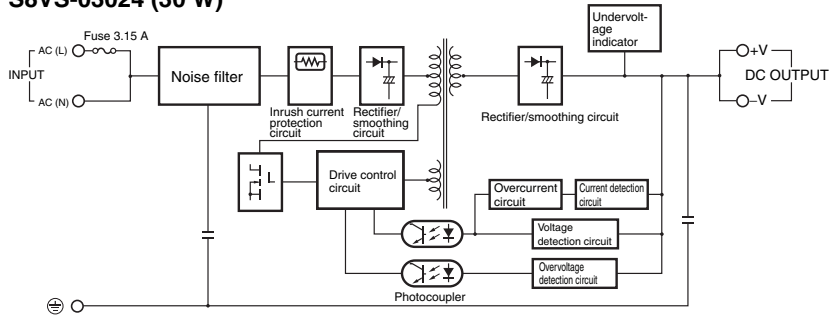

S8VS-06024 (60 W)

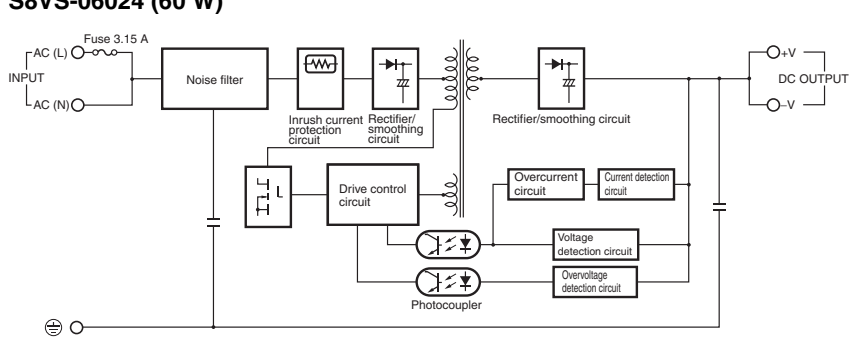

S8VS-12024 (120 W)

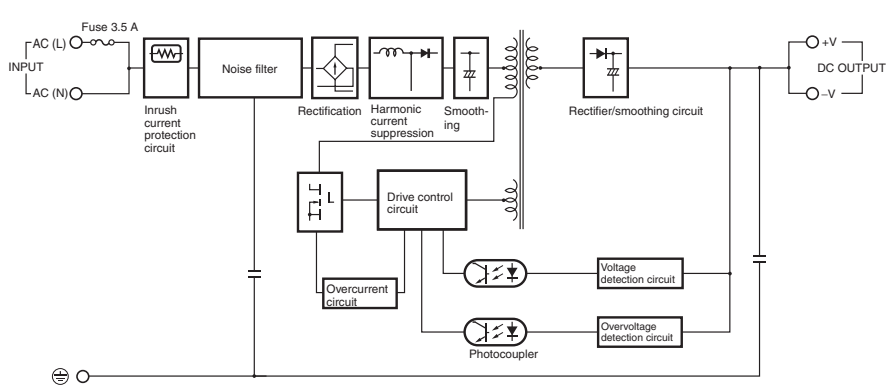

S8VS-24024 (240 W)

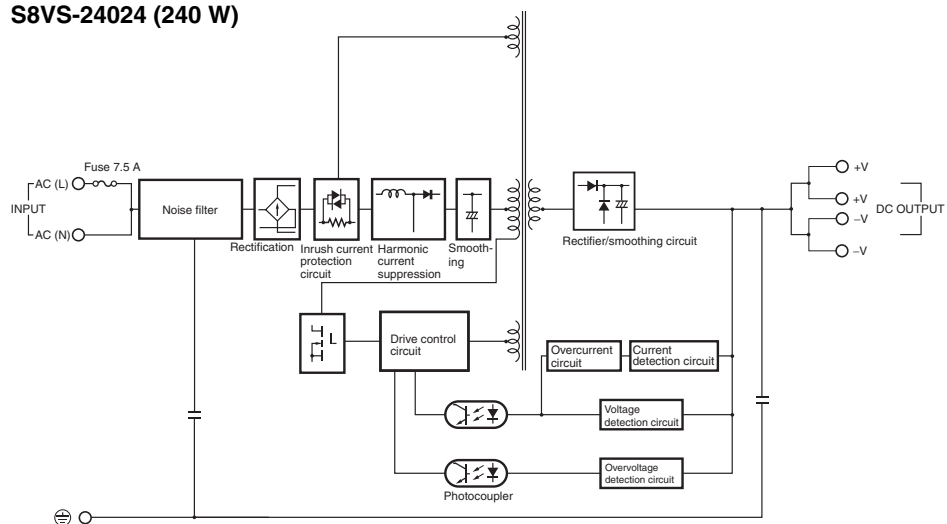

S8VS-48024 (480 W)

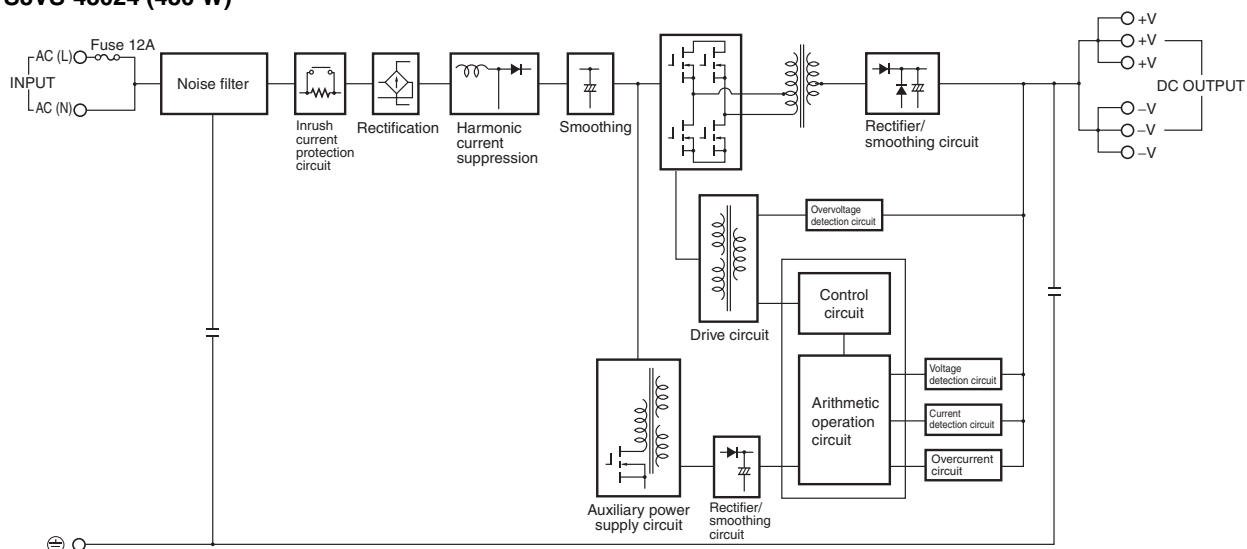

Construction and Nomenclature

Nomenclature

15 W, 30 W Models

S8VS-01524/S8VS-03024

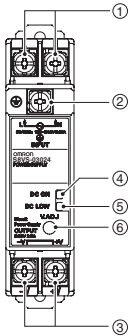

No.	Name	Function
1	AC Input terminals (L), (N)	Connect the input lines to these terminals. *1
2	Protective Earth terminal (PE)	Connect the ground line to this terminal. *2
3	DC Output terminals (-V), (+V)	Connect the load lines to these terminals.
4	Output indicator (DC ON: Green)	Lights while a direct current (DC) output is ON.
5	Undervoltage indicator (DC LOW: Red)	Lights when a drop is detected in the output voltage.
6	Output voltage adjuster (V.ADJ)	Use to adjust the voltage.

*1) The fuse is located on the (L) side. It is NOT user-replaceable.

*2) This is the protective earth terminal specified in the safety standards. Always ground this terminal.

Note: The S8VS-03024 is shown above.

60 W Models

S8VS-06024

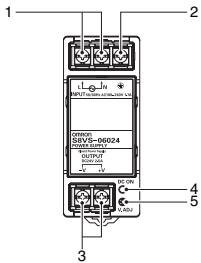

120 W Models

S8VS-12024

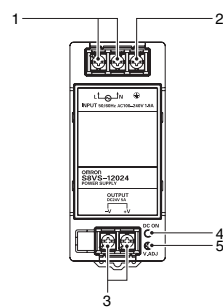

240 W Models

S8VS-24024

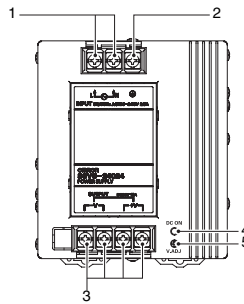

480 W Models

S8VS-48024

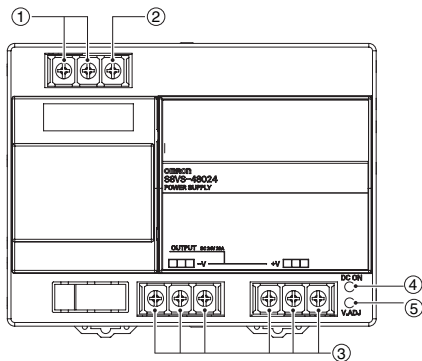

No.	Name	Function
1	AC Input terminals (L), (N)	Connect the input lines to these terminals. *1
2	Protective Earth terminal (PE)	Connect the ground line to this terminal. *2
3	DC Output terminals (-V), (+V)	Connect the load lines to these terminals.
4	Output indicator (DC ON: Green)	Lights while a direct current (DC) output is ON.
5	Output voltage adjuster (V.ADJ)	Use to adjust the voltage.

*1) The fuse is located on the (L) side. It is NOT user-replaceable.

*2) This is the protective earth terminal specified in the safety standards. Always ground this terminal.

Engineering Data

Derating Curve

S8VS-01524

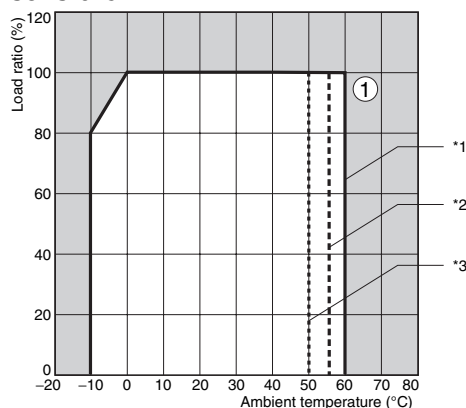

- *1 Standard mounting
- *2 Face-up mounting
- *3 Horizontal mounting

S8VS-03024

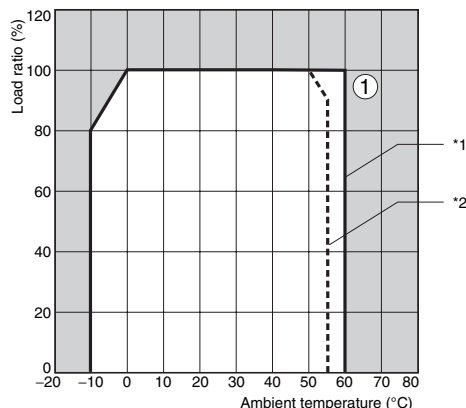

- *1 Standard mounting
- *2 Face-up mounting/Horizontal mounting

- Note:** 1. Internal parts may occasionally deteriorate or be damaged. Do not use the Power Supply in areas outside the derating curve (i.e., the area shown by shading ① in the above graph).
2. If there is a derating problem, use forced air-cooling.
 3. Provide a space of at least 20 mm when using standard mounting and horizontal mounting. If 20 mm is not available, make sure that the space is at least 10 mm. In this case, reduce the corresponding derating curve by 5°C.

S8VS-06024/12024/24024/48024

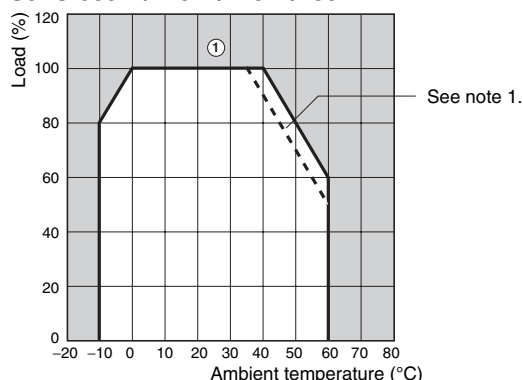

- Note:** 1. Using side mounting bracket for right-side mounting (excluding 240-W models).
2. Internal parts may occasionally deteriorate or be damaged. Do not use the Power Supply in areas outside the derating curve (i.e., the area shown by shading ① in the above graph).
 3. If there is a derating problem, use forced air-cooling.
 4. When using a 480 W model at an input voltage of 95 VAC or less, derate the load by at least 80%.

Mounting

Standard mounting with DIN rail

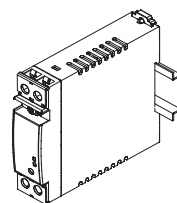

Face-up mounting with DIN rail

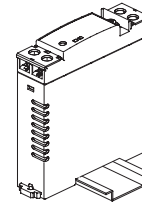

Standard mounting with S82Y-VS30P

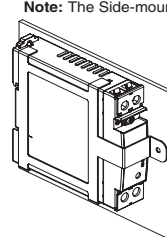

Face-up mounting with S82Y-VS30P

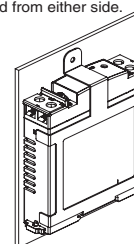

Note: The Side-mounting Bracket can be mounted from either side.

Horizontal mounting with S82Y-VS30P*

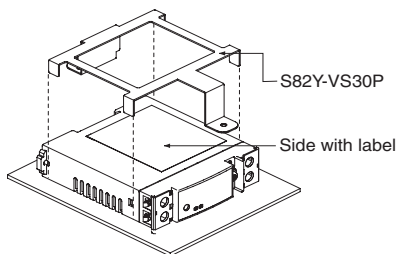

- Note:** 1. Improper mounting will interfere with heat dissipation and may occasionally result in deterioration or damage of internal parts. Use the Product within the derating curve for the mounting direction that is used. Do not use the Power Supply mounted in any way not shown above.
2. Use a mounting bracket (S82Y-VS30P, sold separately) when the Product is mounted horizontally.
 3. Heat dissipation will be adversely affected. When the Product is mounted facing horizontally, always place the side with the label facing horizontally.
 4. Use PFP-M End Plates on the top and bottom of the Power Supply when mounting horizontally on a DIN rail.

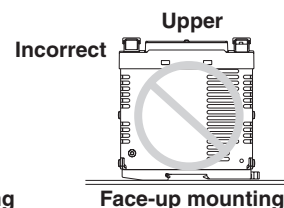
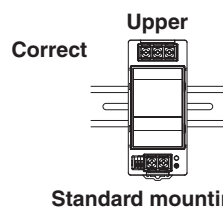

- Note:** Improper mounting will interfere with heat dissipation and may occasionally result in deterioration or damage of internal parts. Use the standard mounting method only.

Overload Protection

The load and the power supply are automatically protected from overcurrent damage by this function. Overload protection is activated if the output current rises above 105% of the rated current. When the output current returns within the rated range overload protection is automatically cleared.

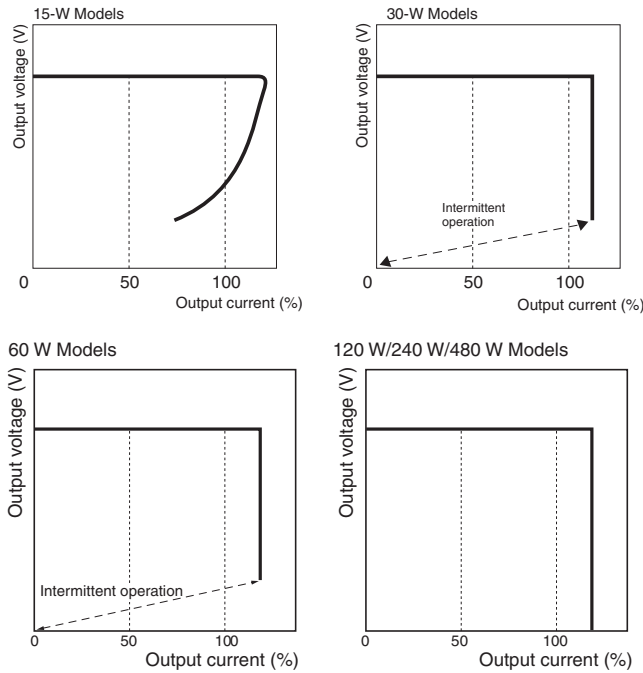

The values shown in the above diagrams are for reference only.

- Note:**
- Internal parts may occasionally deteriorate or be damaged if a short-circuited or overcurrent state continues during operation.
 - Internal parts may possibly deteriorate or be damaged if the Power Supply is used for applications with frequent inrush current or overloading at the load end. Do not use the Power Supply for such applications.

Peak Output Current (S8VS-48024 only)

The peak current must satisfy the following conditions.

Input voltage range: 200 to 240 VAC
 Peak current value: 30 A max.
 Peak current pulse width: 2 s max.
 Cycle: 60 s min.

- Note:**
- Two seconds after the peak current is reached, the peak current limiting function operates to stop the peak current flow.
 - It takes 60 seconds for the peak current to be able to flow again.
 - The peak current limiting function prevents the peak current from flowing at 100 to 120 VAC.

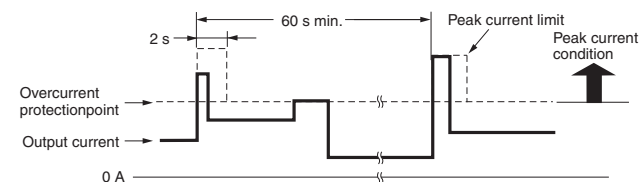

Overvoltage Protection

Consider the possibility of an overvoltage and design the system so that the load will not be subjected to an excessive voltage even if the feedback circuit in the Power Supply fails. This power supply automatically protects itself and the load from overvoltage. When an excessive voltage that is approximately 130% of the rated voltage or more is output, the output voltage is shut OFF. Reset the input power by turning it OFF for at least three minutes and then turning it back ON again.

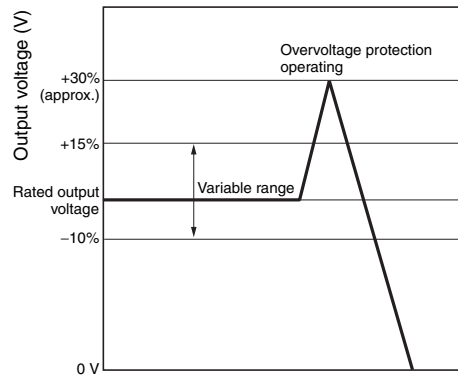

The values shown in the above diagram is for reference only.

- Note:**
- Do not turn ON the power again until the cause of the overvoltage has been removed.
 - The overvoltage protection of the S8VS-01524 uses a zener diode clamp. The output voltage will be clamped at approx. 140% or higher of the rated output voltage (approx. 140% to 190%). If the internal feedback circuit is destroyed by any chance, the load may be destroyed by the clamped output voltage (approx. 140% to 190% of the rated output voltage). The power Supply will not restart if the output is turned OFF by the overvoltage protection operation. If this occurs, replace the Power Supply.

Undervoltage Alarm Indication

LED (DC LOW red) lights to warn of output voltage drop.

Detection voltage is set to approx. 80% (75 to 90%) of the rated output voltage.

- Note:** This function monitors the voltage at the power supply output terminals. To check actual voltage, measure voltage on the load side.

Reference Values (15 W to 480 W Models)

Item	Value	Definition
Reliability (MTBF)	15 W to 240 W: 135,000 hrs min. 480 W: 60,000 hrs min.	MTBF stands for Mean Time Between Failures, which is calculated according to the probability of accidental device failures, and indicates reliability of devices. Therefore, it does not necessarily represent the life of the Product.
Life expectancy	10 yrs. min.	The life expectancy indicates average operating hours under the ambient temperature of 40°C and a load rate of 50%. Normally this is determined by the life expectancy of the built-in aluminum electrolytic capacitor.

Inrush Current, Startup Time, Output Hold Time

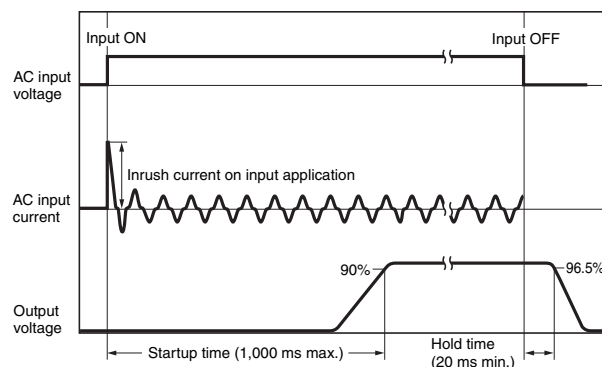

Dimensions

Note: All units are in millimeters unless otherwise indicated.

S8VS-01524 (15 W)
S8VS-03024 (30 W)

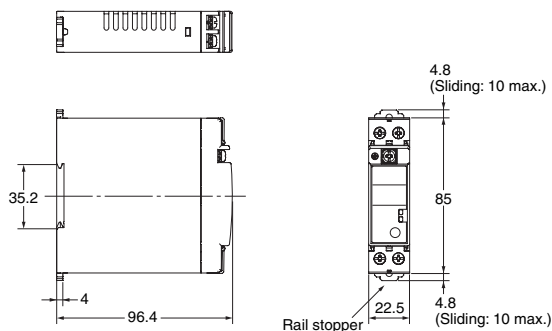

Note: The illustration is the S8VS-03024 model.

S8VS-06024 (60 W)

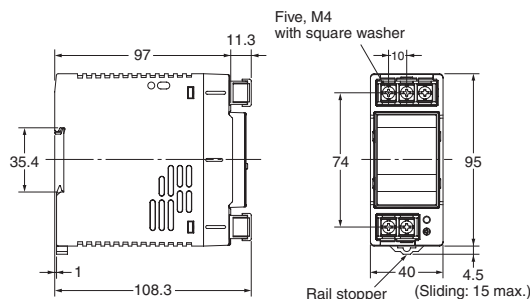

S8VS-12024 (120 W)

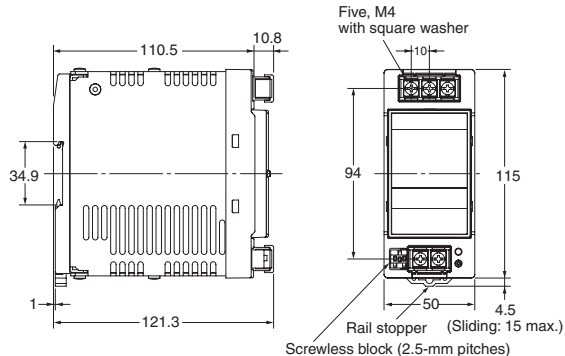

S8VS-24024 (240 W)

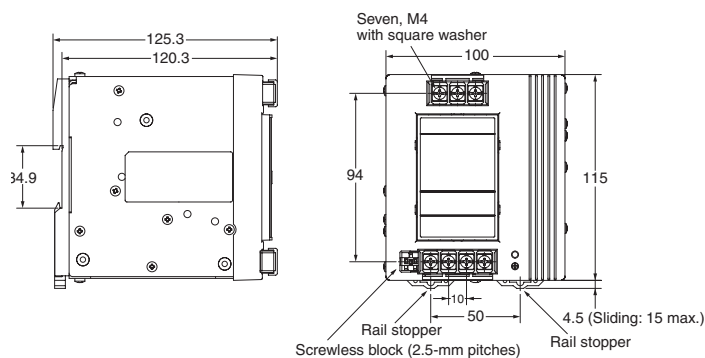

S8VS-48024 (480 W)

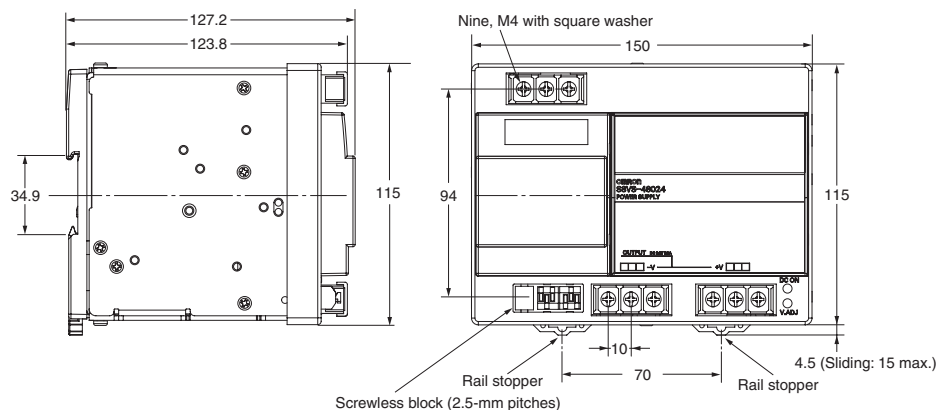

Mounting Brackets

Type	Model	Dimensions	Appearance
Side-mounting Bracket (For 15, 30 W models)	S82Y-VS30P		
Side-mounting Bracket (For 60, 120 W models)	S82Y-VS10S		<p>Left-side mounting Right-side mounting</p>
Side-mounting Bracket (For 240 W models)	S82Y-VS20S		<p>Left-side mounting</p> <p>*Right-side mounting also possible.</p>
Front-mounting Bracket (For 60, 120, and 240 W models) *1	S82Y-VS10F		<p>(For 60 W, 120 W types) (For 240 W type)</p> <p>*Use two S82Y-VS10F brackets for the 240 W type.</p>

*1) Two required to mount a 240 W model.

Note: Brackets cannot be used for 480 W models.

Safety Precautions

CAUTION

Minor electric shock, fire, or Product failure may occasionally occur. Do not disassemble, modify, or repair the Product or touch the interior of the Product.



Minor burns may occasionally occur. Do not touch the Product while power is being supplied or immediately after power is turned OFF.



Fire may occasionally occur. Tighten terminal screws to the specified torque (15 and 30 W models: 0.8 to 1.0 N·m/ 60, 120, 240, and 480 W models: 1.08 N·m).



Minor injury due to electric shock may occasionally occur. Do not touch the terminals while power is being supplied. Always close the terminal cover after wiring.



Minor electric shock, fire, or Product failure may occasionally occur. Do not allow any pieces of metal or conductors or any clippings or cuttings resulting from installation work to enter the Product.



Precautions for Safe Use

Mounting

Take adequate measures to ensure proper heat dissipation to increase the long-term reliability of the Product. Be sure to allow convection in the atmosphere around devices when mounting. Do not use in locations where the ambient temperature exceeds the range of the derating curve.

When cutting out holes for mounting, make sure that cuttings do not enter the interior of the Products.

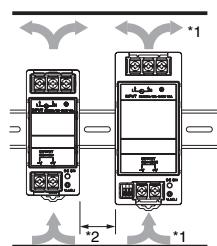

*1. Convection of air
*2. 20 mm min.

(15 W and 30 W Models)

Improper mounting will interfere with heat dissipation and may occasionally result in deterioration or damage of internal parts. Use the Product within the derating curve for the mounting direction that is used.

Use a mounting bracket when the Product is mounted facing horizontally.

Heat dissipation will be adversely affected. When the Product is mounted facing horizontally, always place the side with the label facing upward.

Always provide a space of 20 mm even when mounting horizontal or facing horizontal. If a space of 20 mm is not available, reduce the temperatures given in the derating curve on page 7 by 5°C and provide a space of at least 10 mm.

(60 W, 120 W, 240 W, and 480 W Models)

Improper mounting will interfere with heat dissipation and may occasionally result in deterioration or damage of internal parts. Use the standard mounting method only.

The internal parts may occasionally deteriorate and be broken due to adverse heat radiation. Do not loosen the screw on the side face of the main body.

Wiring

Connect the ground completely. A protective earthing terminal stipulated in safety standards is used. Electric shock or malfunction may occur if the ground is not connected completely.

Minor fire may possibly occur. Ensure that input and output terminals are wired correctly.

Do not apply more than 100 N force to the terminal block when tightening it.

Be sure to remove the sheet covering the Product for machining before power-ON so that it does not interfere with heat dissipation.

Use the following material for the wires to be connected to the S8VS to prevent smoking or ignition caused by abnormal loads.

Recommended Wire Type

15 W and 30 W Models

Stranded wire	Solid wire
AWG20 to 14 (0.5 to 2.0 mm ²)	AWG20 to 16 (0.5 to 1.1 mm ²)

60 W, 120 W, 240 W, and 480 W Models

Model	Recommended wire size
	For screw terminal
S8VS-06024	AWG14 to 20 (Cross section 0.517 to 2.081 mm ²)
S8VS-12024 S8VS-24024	AWG14 to 18 (Cross section 0.823 to 2.081 mm ²)
S8VS-48024	Input terminals AWG 14 to 16 (Cross section 1,309 to 2,081 mm ²) Output terminal (see note 1.) AWG 14 (Cross section 2,081 mm ²)

Note: The rated current for output terminals is 10 A per terminal. Be sure to use multiple terminals simultaneously for current that exceeds the terminal rating.

Installation Environment

Do not use the Power Supply in locations subject to shocks or vibrations. In particular, install the Power Supply as far away as possible from contactors or other devices that are a vibration source.

Install the Power Supply well away from any sources of strong, high-frequency noise and surge.

Operating Life

The life of a Power Supply is determined by the life of the electrolytic capacitors used inside. Here, Arrhenius Law applies, i.e., the life will be cut in half for each rise of 10°C or the life will be doubled for each drop of 10°C. The life of the Power Supply can thus be increased by reducing its internal temperature.

Ambient Operating and Storage Environments

Store the Power Supply at a temperature of -25 to 65°C and a humidity of -25% to 90%.

Do not use the Power Supply in areas outside the derating curve otherwise, internal parts may occasionally deteriorate or be damaged.

Use the Power Supply at a humidity of 25% to 85%.

Do not use the Power Supply in locations subject to direct sunlight.

Do not use locations where liquids, foreign matter, or corrosive gases may enter the interior of Products.

Overcurrent Protection

Internal parts may possibly deteriorate or be damaged if a short-circuited or overcurrent state continues during operation.

Internal parts may possibly deteriorate or be damaged if the Power Supply is used for applications with frequent inrush current or overloading at the load end. Do not use the Power Supply for such applications.

Dielectric Strength Test

If a high voltage is applied between an input and the case (FG), it will pass through the LC of the built-in noise filter and energy will be stored. If the high voltages used for dielectric strength testing are turned ON and OFF with a switch, timer, or similar device, impulse voltage will be generated when the voltage is turned OFF and internal parts may possibly be damaged. To prevent the generation of impulse voltages, reduce the applied voltage slowly with a variable resistor on the test device or turn the voltage ON and OFF at the zero-cross point.

Inrush Current

When two or more Power Supplies are connected to the same input, the total current is the sum of the currents for each Supply. Select fuses and circuit breakers giving sufficient consideration to the fusing or operating characteristics so that fuses will not burn and breakers will not break due to inrush current.

Output Voltage Adjuster (V.ADJ)

The output voltage adjuster (V.ADJ) may possibly be damaged if it is turned with unnecessary force. Do not turn the adjuster with excessive force.

After completing output voltage adjustment, be sure that the output capacity or output current does not exceed the rated output capacity or rated output current.

15 W, 30 W Models

If the output voltage is set to a value less than -10%, the undervoltage alarm function may operate.

60 W, 120 W, 240 W, and 480 W Models

If the output voltage is set to a value less than 20 V (the factory setting), the undervoltage alarm function may operate.

DIN Rail Mounting

To mount the Block on a DIN Rail, hook portion (A) of the Block onto the rail and press the Block in direction (B).

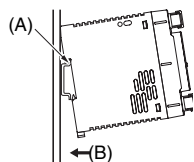

To dismount the Block, pull down portion (C) with a flat-blade screwdriver and pull out the Block.

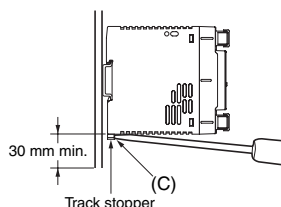

ALL DIMENSIONS SHOWN ARE IN MILLIMETERS.

To convert millimeters into inches, multiply by 0.03937. To convert grams into ounces, multiply by 0.03527.

Series Operation

Two power supplies can be connected in series.

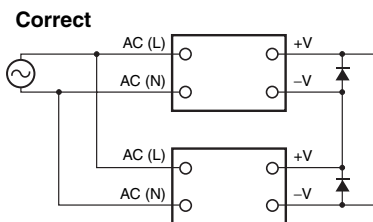

Note: 1. The diode is connected as shown in the figure. If the load is short-circuited, a reverse voltage will be generated inside the Power Supply. If this occurs the Power Supply may possibly deteriorate or be damaged. Always connect a diode as shown in the figure. Select a diode having the following ratings.

Type	Schottky Barrier diode
Dielectric strength (VRRM)	Twice the rated output voltage or above
Forward current (IF)	Twice the rated output current or above

2. Although Products having different specifications can be connected in series, the current flowing through the load must not exceed the smaller rated output current.

Parallel Operation

The Product is not designed for parallel operation.

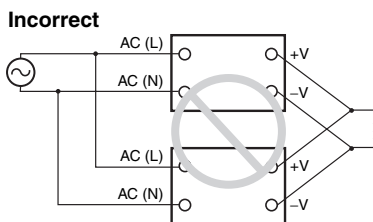

In Case There Is No Output Voltage

The possible cause for no output voltage may be that the overcurrent or overvoltage protection has operated. The internal protection may operate if a large amount of surge voltage such as a lightning surge occurs while turning ON the power supply.

In case there is no output voltage, please check the following points before contacting us:

- Checking overload protected status:
Check whether the load is in overload status or is short-circuited. Remove wires to load when checking.
- Checking overvoltage or internal protection (except for 15 W models):
Turn the power supply OFF once, and leave it OFF for at least 3 minutes. Then turn it ON again to see if this clears the condition.

Buzzing Noise When the Input Is Turned ON

(120 W, 240 W, and 480 W Models)

A harmonic current suppression circuit is built into the Power Supply. This circuit can create noise when the input is turned ON, but it will last only until the internal circuits stabilize and does not indicate any problem in the Product.